

USER MANUAL

19*10W RGBW 4IN1 MOVING HEAD DMX 512 15/23CH



CE

Please read over this manual before operation the light

CONTENTS

Contents.....	0
Important notice.....	1
Attention	1
I. Product Illustration.....	2
II .The installment of led moving head	2
III. The connection of control correspond wire.....	3
IV. Clean maintenance	4
V. Warning.....	5
VI. Difficult processing.....	5
VII. Equipment and appendix.....	5
VIII. Technical paramet.....	6
IX. Functional description.....	6
X. Functional description.....	6
XI. Panel operation.....	7
XII. DMX512channels.....	9

Important notice:

- In this instruction for use contains about the installment and the use aspect important information of the LED moving head. When installing and using, you need to look this usage instruction strictly.
- Before open the LED moving head and if you want to do the repair work, please make sure the power source is at the separation condition.

Attention:

Unceasingly carries on the product improvement about our company the policy, in this instruction booklet carries the data will have the possibility to be able to change in the future, when no longer separate notice change matters concerned. Our company retains when the

product improvement changes the related specification the authority. This instruction booklet publisher cannot be responsible regarding this instruction booklet in information accuracy, also cannot the related consequence which causes regarding these information be responsible.

I. Product Illustration

Our product adopt semiconductor to produce radiation, LED as light origin. With advantage of operation quietly, less power waste, high brightness, gaily-colored, astigmatic, high longevity (60-100 thousands hours), non-calorific etc. Our product apply to use 3 kinds light as red, green, blue LED, synthesize turn colors under election, can create effect of auto gradual change/skip change color, frequent blinking. Can accept control by DMX512, real save power, no pollution green lighting tool.

II .The installment of led moving head

Use the four bolts with M8 size by the clip of the LED moving head to install it. Should guarantee the reliability of the install, this way is to prevent the LED moving head occur swings and skids when it's working. The weight is about 8Kg of each LED moving head, before install, you should confirm the structure whether can support this weight of the LED moving head light. In order to guarantee the security, you also need to install a safety chain in the lamp body side handle.

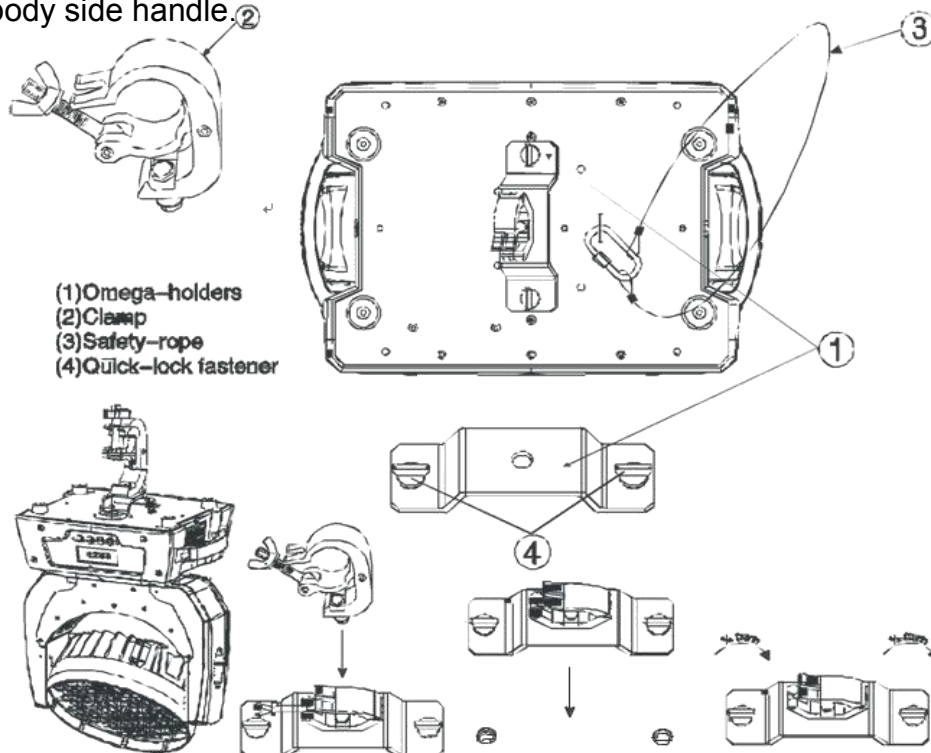

Warning: Do not use the hand of the LED moving head to up and down or fix.

III. The connection of control correspond wire

The connection of controller between the led moving head lamp and respectively led moving head lamp should use the twin core shielded cable, and the diameter of each core at least be 0.3mm. After receives the DMX512 signal, the lamp of nearby the address switch condition will glisten. When it's do not receive the DMX signal, the lamp will in extinguish condition, but if the signal lamp glisten continuously, the mean is the DMX signal is not be correct.

When installing, uses the DMX signal terminal is much better. It can avoid the digital control signal breached by the electrical noise. Generally speaking, the DMX terminal is Cannon plug coupling, it has a 120 ohm resistances between the 2 feet and 3 feet, it will connected on the last led moving head lamp's digital plug of the led moving head lamp chain.

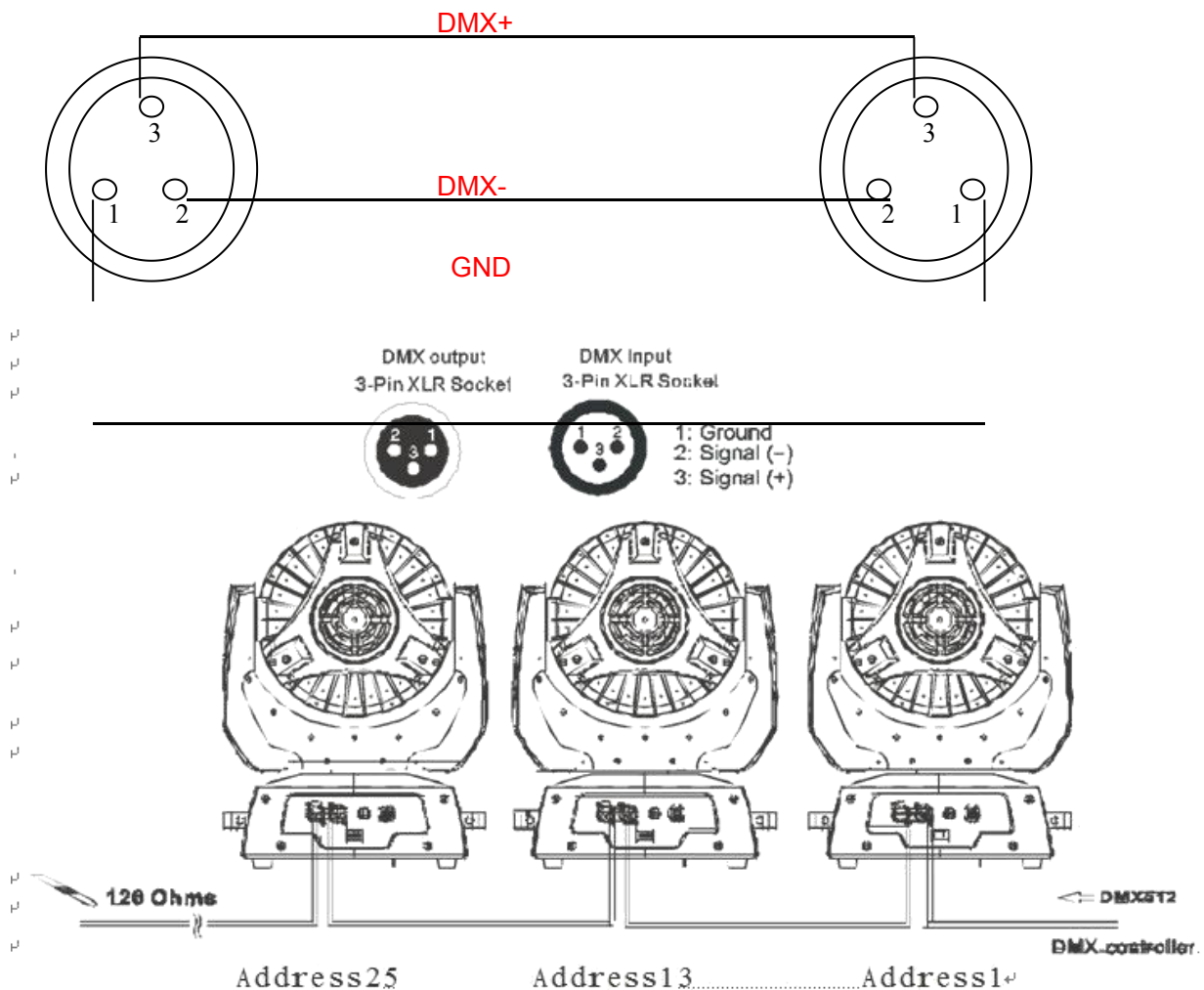

Connecting DMX512 digital signal,
Please using high quality screen line to connect it, for fear interfering.

GND

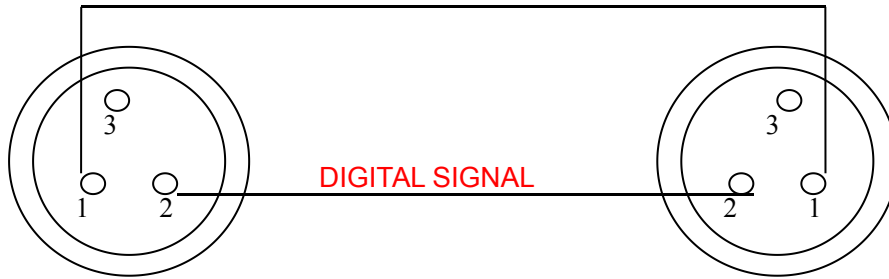

IV. the connection of Power Cable

Use the provided plug to connect the main power to the projector paying attention to the voltage and frequency marked on the panel of the projector. It is recommended that each projector be supplied separately so that they may be individually switched on and off.

IMPORTANT

It is essential that each projector is correctly earthed and that electrical installation conforms to all relevant standards. Power consumption of this projector is 200VA.

The connection of Power cable between the led moving head lamp and respectively led moving head lamp should use the three core shielded cable,

Power cable joint (at most 4pcs) in each other, this is the Connector picture as below:

Important Notice:

In order to avoid overloading the power supply, the power cable can only supply power for at most 4 light

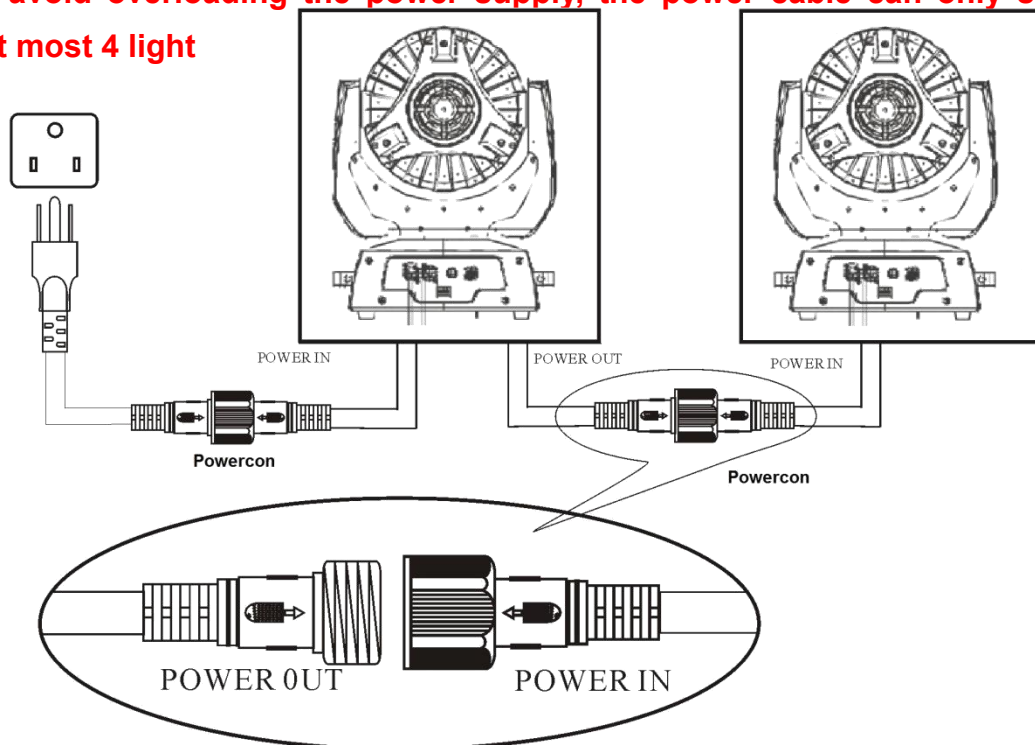

V. Clean maintenance

In order to guarantee the LED moving head lamp can work better, you should keep the

lamp in clean state. Suggests clean the lamp body and fan in each 15 days. For the PVS board, you need clean it on time. When you cleaning the PVC piece, please do not use any soluble cleanser,

VI. Warning

- Don't disassemble and assemble the LED moving head.
- Please do not put the led moving head lamp in water or other any type's liquids and the metal (IP20).
- Do not install the led moving head lamp in the humidity environment.
- Should maintain the minimum 0.5 meter distance between the led moving head lamp and other neighboring object surface.

VII. Difficult processing

Question	Answer
The LED moving head lamp can not start.	Inspects the fuse on the rear panel.
Although shines, but the LED moving head lamp can not accept the instruction of the controller.	Check the digital start address (sees 09th) and also check the connection situation of the communication control line the (to see 03rd).
LED moving head lamp only can work intermittently.	Inspect the power supply and voltage is whether normal.
Do not receive the DMX512 signal	Whether the signal lines do contact good or broken
The light beam appears gloomily.	Inspect the optics part is whether clean.

Other maintains work should by the specialist which has the experience to carry on.

VII. Equipment and appendix

1 led moving head lamp

1PCE

2 the product of USER MANUAL	1PCE
3 Power source connected lines	1PCE
4 signal lines	1PCE

VIII. Technical parameters

Voltage / frequency: 90-130V/180V-240V/50-60Hz

Bulbs: 19*10W RGBW

Power:250 W

Control signal: DMX 512, in sets at the automatic procedure

Channel: 15/23CH, DMX512 channel control

Motion: level 540°, vertical 280°, horizontal and vertical uses the electronic replacement function

Color: 16.7 million kinds of colors changes

Adjusts the light: 0-100 electron adjusts the light, various colors may alone move also may mix the color tone

Strobe: 1-25/second high speed strobe, but single color mixes the color strobe

ZOOM angel: 10.5-30degree adjust

Carton Packing Size: 45*28*38cm

Net Weight: 8.5kg

Gross Weight: 9.5kg

IX. Functional description

Ccontroller can control Moving head light's three axes (PAN axis, TITL axis and Zoom axis), The light have RGBW 4IN1 Multi-Chip LED Lamp, and 3IN1 Tricolor RGB LED Moving Head, and 3color and 4 color, it have DMX mode (can be set DMX address), self-propelled mode (can be set up master-slave), Sound mode (can be set master / slave), The mode selection can be set by the panel or DMX 512 controller (this must be set to DMX mode); The light also have strobe / random frequency flash / strobe out fast and slow / slow forward faster strobe mode, the color jump / gradients

X. Functional Setting

1. Fast operation settings

Controller can quickly set the light's mode, the main interface, followed by "ESC" key to select DMX mode, Auto mode or sound-activated mode,

- In DMX mode: Press "UP" "DOWN" to optional DMX address;
- In the self-propelled mode: Press "UP" "DOWN" to choose master or slave;
- In the sound mode: Press "UP" "DOWN" to choose master or slave

I

X I . Panel operation

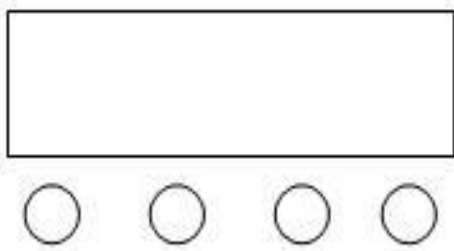

- A. Manual
- B. up
- C. down
- D. Enter

E. LCD Display

A B C D

Operating instructions: Press A will show different function, Press B or C for changing function, Press D for enter.

Detailed function instruction:

- 1、 ◆ [DMX Address Set] for setting DMX address for light
- 2、 ◆ [Work Mode Set] For setting different work mode, 3 modes workable, they are DMX512, AUTO, SOUND Activated..When entering AUTO or SOUND, Light will send DMX signals automatically.
- 3、 ◆ [Invert PAN Set]
- 4、 ◆ [Invert TILT Set]
- 5、 ◆ [Channel Set] For choosing different Channel Mode, two kinds available, 23 channels or 15

Channels.

6、 ◆ [Restore Factory Settings]

7、 ◆ [Reset] For resetting light in AUTO work mode, Press button up or down for choosing language in English or in Chinese.

3. DMX channel function

23 Channels:

CH 1:	pan Adjustment	pan Adjustment	0---255
CH 2:	Pan fine	Pan fine	0---255
CH 3:	Tilt Adjustmen	Tilt Adjustment	0---255
CH 4:	Tilt fine	Tilt fine	0---255
CH 5:	pan/tilt moving speed	from fast to slow	0---255
CH 6:	zoom	from near to far	0---255
CH 7:	dimming	from duck to bright	0---255
CH 8:	strobe	no function	0---15
		strobe from slow to fast	16---255
CH 9:	LEDS color changing	no function	0---15
		LEDS color changing	16---255
CH 10:	LEDS color changing speed	from fast to slow	0---255
CH 11:	R1	from dark to bright	0---255
CH 12:	G1	from dark to bright	0---255
CH 13:	B1	from dark to bright	0---255
CH 14:	W1	from dark to bright	0---255
CH 15:	R2	from dark to bright	0---255
CH 16:	G2	from dark to bright	0---255
CH 17:	B2	from dark to bright	0---255
CH 18:	W2	from dark to bright	0---255
CH 19:	R3	from dark to bright	0---255
CH 20:	G3	from dark to bright	0---255
CH 21:	B3	from dark to bright	0---255
CH 22:	W3	from dark to bright	0---255
CH 23:	Reset	no function	0---127
		reset	128---255

15 Channels:

CH 1:	pan Adjustment	pan Adjustment	0---255
-------	----------------	----------------	---------

CH 2:	Pan fine	Pan fine	0---255
CH 3:	Tilt Adjustment	Tilt Adjustment	0---255
CH 4:	Tilt fine	Tilt fine	0---255
CH 5:	pan/tilt movign speed	from fast to slow	0---255
CH 6:	zoom	from near to far	0---255
CH 7:	Dimming	from dark to brightness	0---255
CH 8:	strobe	no function	0---15
		strobe from slow to fast	16---255
CH 9:	LEDS color changing	no function	0---15
		LEDs' Color changing	16---255
CH 10:	LEDs color changing speed	from fast to slow	0---255
CH 11:	R	from dark to bright	0---255
CH 12:	G	from dark to bright	0---255
CH 13:	B	from dark to bright	0---255
CH 14:	W	from dark to bright	0---255
CH 15:		nofunction	0---127
		reset	128---255

Powered on LED Moving light,conect it to the DMX controller,after receving the DMX signal, the singal mark X disappeared,then light is under DMX controller's control.

Under DMX Mode,connecting multiple lights together,but disconnect with DMX controller, all lights can work in the same step. When connected the first one to controller, the whole group can move in the same step under DMX controller's control.